

**Recommended Amendments to the  
2009 International Residential Code**  
North Central Texas Council of Governments region

The following sections, paragraphs, and sentences of the *2009 International Residential Code* are hereby amended as follows:

---

**\*\*\*Section R101.1; Insert jurisdiction name as follows:**

**R101.1 Title.** These regulations shall be known as the *Residential Code for One- and Two-family Dwellings* of The City of Benbrook hereinafter referred to as "this code."

---

**\*\*Section R102.4; change to read as follows:**

**R102.4 Referenced codes and standards.** The *codes*, when specifically adopted, and standards referenced in this *code* shall be considered part of the requirements of this *code* to the prescribed extent of each such reference. Whenever amendments have been adopted to the referenced *codes* and standards, each reference to said *code* and standard shall be considered to reference the amendments as well. Any reference made to NFPA 70 or the *Electrical Code* shall mean the *Electrical Code* as adopted.

Where differences occur between provisions of this *code* and referenced *codes* and standards, the provisions of this *code* shall apply.

**Exception:** Where enforcement . . . {*remainder of language unchanged*}. . .  
Local Amendment:

R105.2 Work exempt from permit.

Building:

1. One-story detached accessory structures used as tool and storage sheds, playhouses and similar uses, provided the floor area does not exceed 120 square feet.
- 

**\*\*\*Section 108.7; add Section 108.7 to read as follows:**

**108.7 Re-inspection Fee.** A fee as established by city council resolution may be charged when:

1. The inspection called for is not ready when the inspector arrives;
  2. No building address or permit card is clearly posted;
  3. Approved plans are not on the job site available to the inspector;
  4. The building is locked or work otherwise not available for inspection when called;
  5. The job site is red-tagged twice for the same item;
  6. The original red tag has been removed from the job site and/or,
  7. Violations exist on the property including failure to maintain erosion control, trash control or tree protection.
  8. Any re-inspection fees assessed shall be paid before any more inspections are made on that job site.
- 

**\*\*Section R109.1.3; change to read as follows:**

**R109.1.3 Floodplain inspections.** For construction permitted in areas prone to flooding as established by Table R301.2(1), upon . . . *{language unchanged}* . . . construction, the building official may require submission . . . *{language unchanged}*.

**\*\*Section R110 (R110.1 through R110.5); delete the section.**

**\*\*Section R112.2.1 & R112.2.2; delete the sections.**

**\*\*Section R202; change definition of "Townhouse" to read as follows:**

**TOWNHOUSE.** A single-family dwelling unit constructed in a group of three or more attached units separated by property lines in which each unit extends from foundation to roof and with a yard or public way on at least two sides.

**\*\*\*Table R301.2(1); fill in as follows:**

GROUND SNOW LOAD	WIND DESIGN		SEISMIC DESIGN CATEGORY <sup>f</sup>
	SPEED <sup>d</sup> (mph)	Topographic Effects <sup>k</sup>	
5 lb/ft <sup>2</sup>	90 (3-sec-gust)/76 fastest mile	No	A

SUBJECT TO DAMAGE FROM		
Weathering <sup>a</sup>	Frost line depth <sup>b</sup>	Termite <sup>c</sup>
moderate	6"	very heavy

WINTER DESIGN TEMP <sup>e</sup>	ICE BARRIER UNDER-LAYMENT REQUIRED <sup>h</sup>	FLOOD HAZARDS <sup>g</sup>	AIR FREEZING INDEX <sup>i</sup>	MEAN ANNUAL TEMP <sup>j</sup>
22°F	No	local code	69°F	64.9°F

{No change to footnotes}

**\*\*Section R302.1; add exception #6 to read as follows:**

**Exceptions:** *{previous exceptions unchanged}*

- Open metal carport structures may be constructed when also approved within adopted ordinances.

**\*\*\*Section R302.2, Exception; change to read as follows:**

**Exception:** A common two-hour fire-resistance-rated wall assembly, or one-hour fire-resistance-rated wall assembly when equipped with a sprinkler system... *{remainder unchanged}*

**\*\*\*Section R302.2.4, Exception 5; change to read as follows:**

**Exception:**

5. Townhouses separated by a common two-hour fire-resistance-rated wall, or one-hour fire resistant rated wall when equipped with an automatic sprinkler system, *{remainder unchanged}*

---

**\*\*\*Section R302.3; add Exception #3 to read as follows:**

**Exceptions:**

1. *{existing language unchanged}*
  2. *{existing language unchanged}*
  3. Two-family dwelling units that are also divided by a property line through the structure shall be separated as required for townhouses.
- 

**\*\*\*Section 302.5.2; change to read as follows:**

**R302.5.2 Duct penetration.** Ducts in the garage ... *{language unchanged}* ... and shall have no openings into the garage and shall be protected as required by Section 302.11, Item 4.

---

**\*\*\*Section R302.5.3; amend the section as follows:**

**R309.5.3 Other penetrations.** Penetrations through the separation required in Section R302.6 shall be protected as required by Section R302.11, Item 4.

---

**\*\*Section R302.7; change to read as follows:**

**R302.7 Under stair protection.** Enclosed accessible space under stairs shall have walls, under stair surface and any soffits protected on the enclosed side with 5/8-inch (15.8 mm) fire-rated gypsum board or one-hour fire-resistive construction.

**\*\*Section R303.3, Exception; change to read as follows:**

**Exception:** The glazed areas shall not be required where artificial light and a mechanical ventilation system, complying with one of the following, are provided.

1. The minimum ventilation rates shall be 50 cfm (24 L/s) for intermittent ventilation or 20 cfm (10 L/s) for continuous ventilation. Ventilation air from the space shall be exhausted directly to the outside.
  2. Bathrooms that contain only a water closet, a lavatory, or water closet and a lavatory may be ventilated with an approved mechanical re-circulating fan or similar device designed to remove odors from the air.
- 

**\*\*\*Section 602.6.1; amend the following:**

**R602.6.1 Drilling and notching of top plate.** When piping or ductwork is placed in or partly in an exterior wall or interior load-bearing wall, necessitating cutting, drilling or notching of the top plate by more than 50 percent of its width, a galvanized metal tie not less than 0.054 inch thick (1.37 mm) (16 Ga) and 5 inches (127 mm) wide shall be fastened across and to the plate at each side of the opening with not less than eight 10d (0.148 inch diameter) having a minimum length of 1 ½ inches (38 mm) at each side or equivalent. Fasteners will be offset to prevent splitting of the

top plate material. The metal tie must extend a minimum of 6 inches past the opening. See figure R602.6.1.

---

**\*\*Figure R602.6.1; delete the figure and insert the following figure:**

WALL CONSTRUCTION

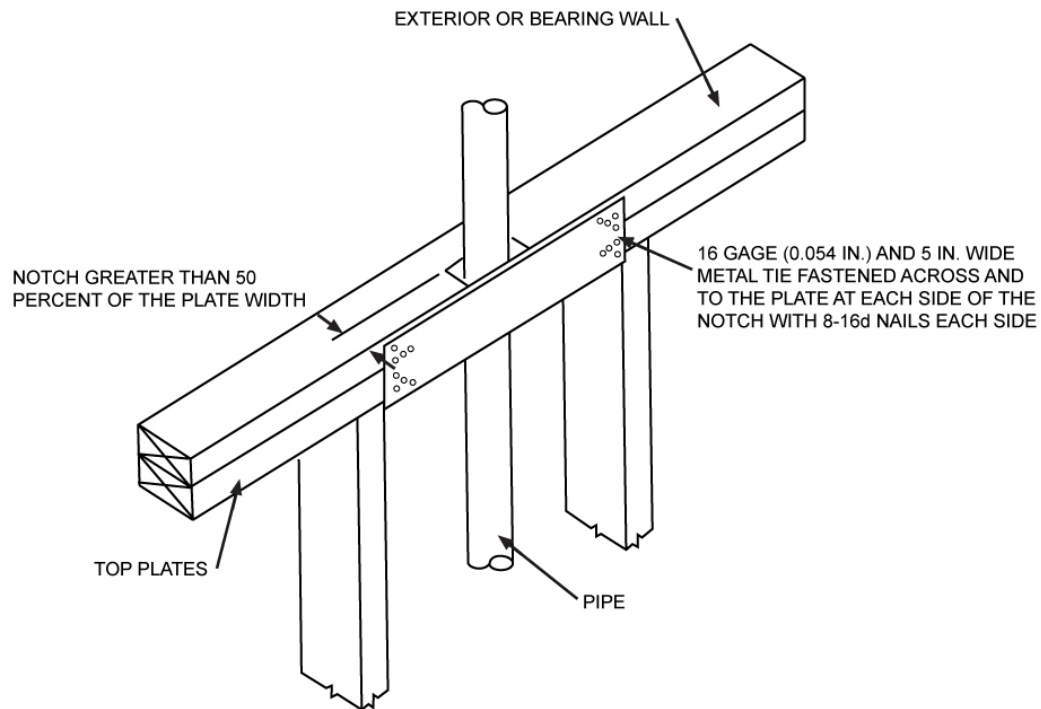

For SI: 1 inch = 25.4 mm

FIGURE R602.6.1  
TOP PLATE FRAMING TO ACCOMMODATE PIPING

---

**\*\*Section R703.7.4.1; add a second paragraph to read as follows:**

In stud framed exterior walls, all ties shall be anchored to studs as follows:

1. When studs are 16 in (407 mm) o.c., stud ties shall be spaced no further apart than 24 in (737 mm) vertically starting approximately 12 in (381 mm) from the foundation; or
  2. When studs are 24 in (610 mm) o.c., stud ties shall be spaced no further apart than 16 in (483 mm) vertically starting approximately 8 in (254 mm) from the foundation.
-

**\*\*\*Section R902.1; Amend and add exception #3 to read as follows:**

**R902.1 Roofing covering materials.** Roofs shall be covered with materials as set forth in Sections R904 and R905. Class A, B, or C roofing shall be installed *{remainder unchanged}*

**Exceptions:**

1. {unchanged}
  2. {unchanged}
  3. Non-classified roof coverings shall be permitted on one-story detached *accessory structures* used as tool and storage sheds, playhouses and similar uses, provided the floor area does not exceed (area defined by jurisdiction).
- 

**\*\*Section R907.1; add a sentence to read as follows:**

All individual replacement shingles or shakes shall comply with Section R902.1,

---

**\*\*\*Section N1101.2; add Section N1101.2.2 to read as follows:**

**N1101.2.2 Compliance software tools.** Software tools used to demonstrate energy code compliance utilizing the UA alternative approach shall be approved by the building official. The PNL program **REScheck™** is not acceptable for residential compliance.

**Exception:** When **REScheck™** “UA Trade-off” compliance approach or the UA Alternate compliance approach method is used, the compliance certificate must demonstrate that the maximum glazed area does not exceed 15% of the conditioned floor area.

---

**\*\*\*Section N1102.1; change to read as follows:**

**N1102.1 Insulation and fenestration criteria.** The building thermal envelope shall meet the requirements of Table N1102.1 based on the climate zone specified in Table N1101.2. The use of Tables N1102.1 and N1102.1.2 are limited to a maximum glazing area of 15% window area to floor area ratio.

---

**\*\*Section N1102.2.12; add Section N1102.2.12 to read as follows:**

**N1102.2.12. Insulation installed in walls.** Insulation batts installed in walls shall be totally surrounded by an enclosure on all sides consisting of framing lumber, gypsum, sheathing, wood structural panel sheathing or other equivalent material approved by the *building official*.

---

**\*\*\*Section M1305.1.3; change to read as follows:**

**M1305.1.3 Appliances in attics.** *Attics* containing *appliances* requiring access shall be provided . . . *{bulk of paragraph unchanged}* . . . sides of the *appliance* where access is required. The clear access opening dimensions shall be a minimum of 20 inches by 30 inches (508 mm by 762 mm), or larger and large enough to allow removal of the largest *appliance*. As a minimum, access to the *attic* space, provide one of the following:

1. A permanent stair.
2. A pull down stair with a minimum 300 lb (136 kg) capacity.
3. An access door from an upper floor level.

4. Access Panel may be used in lieu items 1, 2, and 3 with prior approval of the *building official* due to building conditions.

**Exceptions:**

1. The passageway and level service space are not required where the *appliance* can be serviced and removed through the required opening.
  2. Where the passageway is unobstructed...*{remainder unchanged}*
- 

**\*\*\*Section M1305.1.3.1; add text to read as follows:**

**M1305.1.3.1 Electrical requirements.** A luminaire controlled by a switch located at the required passage-way opening and a receptacle outlet shall be installed at or near the *appliance* location in accordance with Chapter 39. Low voltage wiring of 50 Volts or less shall be installed in a manner to prevent physical damage.

---

**\*\*Section M1305.1.4.1; change to read as follows:**

**M1305.1.4.1 Ground clearance.** *Equipment* and *appliances* supported from the ground shall be level and firmly supported on a concrete slab or other *approved* material extending above the adjoining ground a minimum of 3 inches (76 mm). Appliances suspended from the floor shall have a clearance of not less than 6 inches (152 mm) above the ground.

---

**\*\*Section M1305.1.4.3; add text to read as follows:**

**M1305.1.4.3 Electrical requirements.** A luminaire controlled by a switch located at the required passage-way opening and a receptacle outlet shall be installed at or near the *appliance* location in accordance with Chapter 39. Low voltage wiring of 50 Volts or less shall be installed in a manner to prevent physical damage.

---

**\*\*Section M1307.3.1; delete.**

---

**\*\*\*Section M1411.3; change to read as follows:**

**M1411.3 Condensate disposal.** Condensate from all cooling coils or evaporators shall be conveyed from the drain pan outlet to a sanitary sewer through a trap, by means of a direct or indirect drain. *{remainder unchanged}*

---

**\*\*Section M1411.3.1, Items 3 and 4; add text to read as follows:**

**M1411.3.1 Auxiliary and secondary drain systems.** *{bulk of paragraph unchanged}*

1. *{text unchanged}*
2. *{text unchanged}*
3. An auxiliary drain pan... *{bulk of text unchanged}*... with Item 1 of this section. A water level detection device may be installed only with prior approval of the *building official*.

4. A water level detection device... *{bulk of text unchanged}*... overflow rim of such pan. A water level detection device may be installed only with prior approval of the *building official*.

---

**\*\*\*Section M1411.3.1.1; add text to read as follows:**

**M1411.3.1.1 Water-level monitoring devices.** On down-flow units... *{bulk of text unchanged}* ...installed in the drain line. A water level detection device may be installed only with prior approval of the *building official*.

---

**\*\*\*Section M1501; add new Section M1501.2 to read as follows:**

**M1501.2 Material and size.** Exhaust ducts shall have a smooth interior finish and shall be constructed of metal a minimum 0.016-inch (0.4mm) thick. The exhaust duct size shall be 4 inches (102 mm) nominal in diameter. Duct size shall not be reduced along its developed length or at termination.

---

**\*\*\*Section M1501; add new Section M1501.3 to read as follows:**

**M1501.3 Specified length.** The maximum length of the exhaust duct shall be 35 feet (10668 mm) from the connection to the transition duct from the *appliance* to the outlet terminal. Where fittings are used, the maximum length of the exhaust duct shall be reduced in accordance with Table M1502.4.4.1.

---

**\*\*Section M2005.2; change to read as follows:**

**M2005.2 Prohibited locations.** Fuel-fired water heaters shall not be installed in a room used as a storage closet. Water heaters located in a bedroom or bathroom shall be installed in a sealed enclosure so that *combustion air* will not be taken from the living space. Access to such enclosure may be from the bedroom or bathroom when through a solid door, weather-stripped in accordance with the exterior door air leakage requirements of the *International Energy Conservation Code* and equipped with an *approved* self-closing device. Installation of direct-vent water heaters within an enclosure is not required.

---

**\*\*Section G2408.3 (305.5); delete.**

---

**\*\*Section G2412.5 (401.5); add a second paragraph to read as follows:**

Both ends of each section of medium pressure gas piping shall identify its operating gas pressure with an *approved* tag. The tags are to be composed of aluminum or stainless steel and the following wording shall be stamped into the tag:

"WARNING  
1/2 to 5 psi gas pressure  
Do Not Remove"

---

**\*\*Section G2413.3 (402.4.3); add an exception to read as follows:**

**Exception:** Corrugated stainless steel tubing (CSST) shall be a minimum of 1/2" (18 EDH).

---

**\*\*Section G2415.9.1 (404.9.1); delete.**

---

**\*\*Section G2415.10 (404.10); change to read as follows:**

**G2415.10 (404.10) Minimum burial depth.** Underground *pipng systems* shall be installed a minimum depth of 18 inches (457 mm) below grade, except as provided for in Section G2415.10.1.

---

**\*\*Section G2417.1 (406.1); change to read as follows:**

**G2417.1 (406.1) General.** Prior to acceptance and initial operation, all *pipng* installations shall be inspected and *pressure tested* to determine that the materials, design, fabrication, and installation practices comply with the requirements of this *code*. The *permit* holder shall make the applicable tests prescribed in Sections 2417.1.1 through 2417.1.5 to determine compliance with the provisions of this *code*. The *permit* holder shall give reasonable advance notice to the *building official* when the *pipng system* is ready for testing. The *equipment*, material, power and labor necessary for the inspections and test shall be furnished by the *permit* holder and the *permit* holder shall be responsible for determining that the work will withstand the test pressure prescribed in the following tests.

---

**\*\*Section G2417.4; change to read as follows:**

**G2417.4 (406.4) Test pressure measurement.** Test pressure shall be measured with a manometer or with a pressure-measuring device designed and calibrated to read, record, or indicate a pressure loss caused by leakage during the *pressure test* period. The source of pressure shall be isolated before the *pressure tests* are made. Gauges used to measure...  
{remainder unchanged}

---

**\*\*Section G2417.4.1; change to read as follows:**

**G2417.4.1 (406.4.1) Test pressure.** The test pressure to be used shall be not less than 3 psig (20 kPa gauge), or at the discretion of the *Building Official*, the *pipng* and *valves* may be tested at a pressure of at least six (6) inches (152 mm) of mercury, measured with a manometer or slope gauge. For tests requiring a pressure of 3 psig, shall utilize a dial with a minimum diaphragm diameter of three and one half inches (3 1/2"), a set hand, 1/10 pound incrementation and pressure range not to exceed 6 psi for tests requiring a pressure of 3 psig. For tests requiring a pressure of 10 psig, diaphragm gauges shall utilize a dial with a minimum diameter of three and one-half inches (3 1/2"), a set hand, a minimum of 2/10 pound incrementation and a pressure range not to exceed 20 psi.

For welded *pipng*, and for *pipng* carrying gas at pressures in excess of fourteen (14) inches water column pressure (3.48 kPa) (1/2 psi) and less than 200 inches of water column pressure (52.2 kPa) (7.5 psi), the test pressure shall not be less than ten (10) pounds per square inch (69.6 kPa). For *pipng* carrying gas at a pressure that exceeds 200 inches of water column (52.2 kPa) (7.5 psi), the test pressure shall be not less than one and one-half times the proposed maximum working pressure.

---

**\*\*Section G2417.4.2; change to read as follows:**

**G2417.4.2 (406.4.2) Test duration.** The test duration shall be held for a length of time satisfactory to the *Building Official*, but in no case for less than fifteen (15) minutes. For welded *pipng*, and for *pipng* carrying gas at pressures in excess of fourteen (14) inches water column pressure (3.48 kPa), the test duration shall be held for a length of time satisfactory to the *Building Official*, but in no case for less than thirty (30) minutes.

---

**\*\*Section G2420.1 (406.1); add Section G2420.1.4 to read as follows:**

**G2420.1.4 Valves in CSST installations.** Shutoff *valves* installed with corrugated stainless steel (CSST) *pipng systems* shall be supported with an approved termination fitting, or equivalent support, suitable for the size of the *valves*, of adequate strength and quality, and located at intervals so as to prevent or damp out excessive vibration but in no case greater than 12-inches from the center of the *valve*. Supports shall be installed so as not to interfere with the free expansion and contraction of the system's *pipng*, fittings, and *valves* between anchors. All *valves* and supports shall be designed and installed so they will not be disengaged by movement of the supporting *pipng*.

---

**\*\*\*Section G2420.5.1 (409.5.1); add text to read as follows:**

**G2420.5.1 (409.5.1) Located within the same room.** The shutoff valve... *{bulk of paragraph unchanged}*... in accordance with the appliance manufacturer's instructions. A secondary shutoff valve must be installed within 3 feet (914 mm) of the firebox if appliance shutoff is located in the firebox.

---

**\*\*Section G2421.1 (410.1); add text and Exception to read as follows:**

**G2421.1 (410.1) Pressure regulators.** A line *pressure regulator* shall be ... *{bulk of paragraph unchanged}*... *approved* for outdoor installation. Access to *regulators* shall comply with the requirements for access to *appliances* as specified in Section M1305.

**Exception:** A passageway or level service space is not required when the *regulator* is capable of being serviced and removed through the required *attic* opening.

---

**\*\*\*Section G2422.1.2.3 (411.1.3.3); delete Exception 1 and Exception 4.**

**G2422.1.2.3 (410.1) Pressure regulators.** A line *pressure regulator* shall be ... *{bulk of paragraph unchanged}*... *approved* for outdoor installation. Access to *regulators* shall comply with the requirements for access to *appliances* as specified in Section M1305.

**Exception:** A passageway or level service space is not required when the *regulator* is capable of being serviced and removed through the required *attic* opening.

---

**\*\*Section G2439.5 (614.6); change text to read as follows:**

**G2439.5 (614.6) Domestic clothes dryer exhaust ducts.** Exhaust ducts for domestic *clothes dryers* shall conform to the requirements of Sections G2439.5.1 through G2439.5.7. The size of duct shall not be reduced along its developed length nor at the point of termination.

---

**\*\*Section G2445.2 (621.2); add Exception to read as follows:**

**G2445.2 (621.2) Prohibited use.** One or more *unvented room heaters* shall not be used as the sole source of comfort heating in a *dwelling unit*.

**Exception:** Existing *approved unvented room heaters* may continue to be used in *dwelling units*, in accordance with the *code* provisions in effect when installed, when *approved* by the *Building Official* unless an unsafe condition is determined to exist as described in *International Fuel Gas Code* Section 108.7 of the Fuel Gas Code.

---

**\*\*Section G2448.1.1 (624.1.1); change to read as follows:**

**G2448.1.1 (624.1.1) Installation requirements.** The requirements for *water heaters* relative to access, sizing, *relief valves*, drain pans and scald protection shall be in accordance with this *code*.

---

**\*\*Section P2503.6; change to read as follows:**

**P2503.6 Shower liner test.** Where shower floors and receptors are made water tight by the application of materials required by Section P2709.2, the completed liner installation shall be tested. The pipe from the shower drain shall be plugged water tight for the test. Water shall be held in the section under test for a period of 15 minutes. The system shall prove leak free by visual inspection.

---

**\*\*Section P2503.6; change to read as follows:**

**P2503.6 Shower liner test.** Where shower floors and receptors are made water tight by the application of materials required by Section P2709.2, the completed liner installation shall be tested. The pipe from the shower drain shall be plugged water tight for the test. Water shall be held in the section under test for a period of 15 minutes. The system shall prove leak free by visual inspection.

---

**\*\*Section P2717.2; change text to read as follows:**

**P2717.2 Sink and dishwasher.** A sink and dishwasher are permitted ... *{bulk of text unchanged}* ... wye fitting to the sink tailpiece. The waste line of a domestic dishwashing machine discharging into a kitchen sink tailpiece shall connect to a deck mounted *air break*.

---

**\*\*Section P2717.3; change text to read as follows:**

**P2717.3 Sink, dishwasher and food grinder.** The combined discharge ... *{bulk of text unchanged}* ... head of the food grinder. The waste line of a domestic dishwashing machine

discharging into a kitchen sink tailpiece or food waste grinder shall connect to a deck mounted *air break*.

**\*\*Section P2801.6; add Exception to read as follows:**

**Exceptions:**

1. Elevation of the ignition source is not required for water heaters that are listed as flammable vapor resistant and for installation without elevation.
2. Electric Water Heater.

**\*\*Section P2803.6.1; changed to read as follows:**

1. Not be directly connected to the drainage system.
2. Discharge through an air gap.
3. Not be smaller than the diameter of the outlet of the valve served and shall discharge full size to the air gap.
4. Serve a single relief device and shall not connect to piping serving any other relief device or equipment.

**Exception:** Multiple relief devices may be installed to a single T & P discharge piping system when approved by the administrative authority and permitted by the manufactures installation instructions and installed with those instruction.

5. Discharge to the pan, an indirect waste receptor or to the outdoors. Where discharging to the outdoors in areas subject to freezing, discharge piping shall be first piped to an indirect waste receptor through an air gap located in a conditioned area.
6. Discharge in a manner that does not cause personal injury or structural damage.
7. Discharge to a termination point that is readily observable by the building occupants.
8. Not be trapped.
9. Be installed so as to flow by gravity.
10. Not terminate more than 6 inches (152mm) above the floor the floor or waste receptor.
11. Not have a threaded connection at the end of such piping.
12. Not have valves or tee fittings.
13. Be constructed of those materials listed in Section 605.4 or materials tested, rated and approved for such use in accordance with ASME A112.4.1.

**Local Amendments:**

1. Use of flexible copper on T&P discharge pipe is prohibited.
2. If water heater is located in the interior of the residence with no method to drain the pan a water alarm or shut-off device shall be installed.
3. If unable to discharge T&P outside discharge means will be established by the Building Official on a case by case basis.

---

**\*\*Section P2902.5.3; change to read as follows:**

**P2902.5.3 Lawn irrigation systems.** The potable water supply to lawn irrigation systems shall be protected against backflow by a reduced pressure principle backflow preventer. A valve shall not be installed downstream from an atmospheric vacuum breaker. Where chemicals are introduced into the system, the potable water supply shall be protected against backflow by a reduced pressure principle backflow preventer.

---

**\*\*Section P3005.2.6; change to read as follows:**

**P3005.2.6 Upper terminal.** Each horizontal drain shall be provided with a cleanout at its upper terminal

**Exception:** Cleanouts may be omitted on a horizontal drain less than five (5) feet (1524 mm) in length unless such line is serving sinks or urinals.

---

**\*\*Section P3111; delete.**

---

**\*\*Section P3112.2; delete and replace with the following:**

**P3112.2 Installation.** Traps for island sinks and similar equipment shall be roughed in above the floor and may be vented by extending the vent as high as possible, but not less than the drain-board height and then returning it downward and connecting it to the horizontal sink drain immediately downstream from the vertical fixture drain. The return vent shall be connected to the horizontal drain through a wye-branch fitting and shall, in addition, be provided with a foot vent taken off the vertical fixture vent by means of a wye-branch immediately below the floor and extending to the nearest partition and then through the roof to the open air or may be connected to other vents at a point not less than six (6) inches (152 mm) above the flood level rim of the fixtures served. Drainage fittings shall be used on all parts of the vent below the floor level and a minimum slope of one-quarter (1/4) inch per foot (20.9 mm/m) back to the drain shall be maintained. The return bend used under the drain-board shall be a one (1) piece fitting or an assembly of a forty-five (45) degree (0.79 radius), a ninety (90) degree (1.6 radius) and a forty-five (45) degree (0.79 radius) elbow in the order named. Pipe sizing shall be as elsewhere required in this Code. The island sink drain, upstream of the return vent, shall serve no other fixtures. An accessible cleanout shall be installed in the vertical portion of the foot vent.

---

## **Adopt Appendix G Swimming Pools, Spa's and Hot Tubs**

### **Local Amendments**

Change AG105.2 1. to read

The top of the barrier shall be a minimum of 60 inches from grade measured on the side which faces away from the swimming pool.

Change AG105.2 4. to read

When the barrier is composed of horizontal and vertical members and the distance between the horizontal members is less than 45 inches (1143mm), the horizontal members shall be located on the swimming pool side of the fence. If circumstances arise where the barriers cannot be installed alternate methods may be authorized by the Building Official on a case by case basis.